



Handling and Installation Instructions of Stainless Steel Expansion Joints
In accordance with Pressure Equipment Directive 2014/68/EU / DIN EN 30681

Handling and Installation Instructions of Stainless Steel Expansion Joints..... 1

Intended use 2

Instructions for transportation and storage 2

Assembly instructions 2

Tube guide distances..... 4

Assembly of flanged expansion joints 4

Pretensioning, installation lengths and torsion 5

Maintenance 6

Warranty 6

Environmental protection 6

Expansion joints in accordance with DGRL 2014/68/EU 6

Hazards and risk analysis 7

Applicable standards..... 8





Expansion joints comprise of a metal bellows and connecting parts in the form of tube supports, flanges or special connections made from steel or stainless steel, installed at both ends. **The metal bellows of the expansion joints are manufactured from multiple** thin-wall sleeves, joined into one another. The material used is stainless steel, resistant to corrosion and acids, or special material, with high resistance to corrosion and temperature (e.g., duplex stainless steels, nickel-based alloys etc.).

Intended use

Use expansion joints only for their intended application. The parameters required for this and the design required by it can be determined from the following list

http://www.flexomat.de/pdf/flexomat_typschiessel.pdf

Further, the technical documents, manufacturer's declaration, declaration of conformity and the marking on the expansion joint are also applicable.

Instructions for transportation and storage

For **transportation**, the expansion joint, particularly the metal bellows, must be protected in a suitable manner against any damage. During acceptance of the goods, they must be immediately checked for signs of damage during transportation and immediately reported (note on the delivery note of the carrier and damage symptoms).

For storing the expansion joints, pay particular attention to the following:

- cool, dry and free of dust
- Prevent effects of corrosion-carrying media
- Do not stack the expansion joints

Assembly instructions

It must be ensured that expansion joints are installed stress-free without additional external influences.

Torsion and impermissible misalignment of the compensators must be avoided during installation.

Pretensioning of the expansion joints is only permitted for the (axial, lateral, angular) movements for which the compensator was constructed and designed.

For assembly, the protection of the corrugations must be maintained in a suitable manner against any damage (e.g. welding spatter, impacting material or tools). No foreign objects are permitted between the corrugations, internally or externally.

Transportation and assembly locks must not be removed before installation. If no assembly locks are present, the expansion joint must be locked during installation. Before commissioning, it is





mandatory to remove the locking parts **marked yellow**. When disassembling the expansion joint, this must be locked again.

These locks are **not** suitable for locking the expansion joint for a pressure test. For this purpose, separate constructional measures must be agreed with the manufacturer.

Transportation and assembly locks must **not** be used as slinging points for assembly equipment. Unless otherwise specified, enquire at Flexomat GmbH about suitable points.

When installing expansion joints with **inner sleeve**, **observe the direction of flow**. Here, the outlet aperture of the guide tube depends on the direction of flow. The **direction of flow arrow** is marked on the nameplate and indicates the direction of flow.

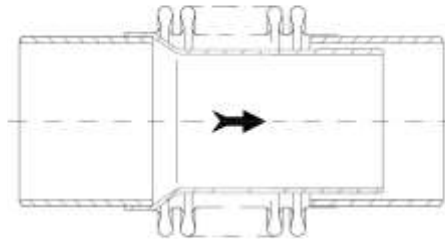

Intended Insulation in the area of the expansion joint must be agreed with Flexomat GmbH.

During welding tasks, make sure that no electrical power is conducted through the metal bellows. The metal bellows must be sufficiently protected against welding spatter.

The expansion joint must not be used as an earthing connection.

Pressure and leak tightness checks must only be carried out after the fixed and friction bearings are correctly assembled and checked. The test pressure must only be applied **in the cold state** without lifting load. The expansion joint must be locked, if necessary, against elongation and buckling.

Using suitable technical measures, it is imperative to prevent a load **above the specified test pressure**.

Pressure surges resulting from water impact or switching procedures that could result in bursting (overpressure) or implosion (vacuum) are **not permitted**.

The fluid group selected when classifying pressure devices, in accordance with DGRL2014/68/EU, must be maintained during operation of the expansion joint. Performance data of the expansion joint must be compared to the operating and test conditions of the system.

In the case of **unknown fluids** or of **fluids not specified** to the manufacturer, the suitability of the component and all materials for the actual operating conditions must be checked **before**





commissioning. The responsibility for this inspection lies with the operating company of the system.

Tube guide distances

Only 1 expansion joint must be installed between 2 fixed bearings. Expansion of this section must be less than the max. possible expansion absorption of the expansion joint.

The expansion joint must be installed as **close to a fixed bearing** ($L1 \leq 4 \times DN$) as possible. In this case, only one friction bearing is required on the opposing side of the expansion joint.

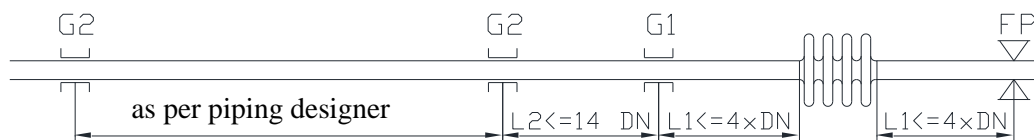

G1 and G2 => Friction bearing FP => Fixed bearing

The lines must be well routed and flush, so that the anticipated motion can be optimally absorbed by the expansion joint.

Missing friction or fixed bearings in the systems cannot be replaced by external protection or internal guide tubes.

Assembly of flanged expansion joints

When assembling the expansion joints with flanges, make sure that the corrugations of the metal bellows are **not damaged** by the tools and connecting elements used (e.g. spanner, bolts, hexagon nuts etc.).

During installation of the expansion joint, a **minimum distance of 3mm** must be maintained between the end of the connecting elements and bellow flank. If this is not possible, check to see if a **shorter bolt** with a hexagon nut, for example in accordance with DIN 936 (low form) can be used or if assembly of an **additional washer** under the bolt head might be considered.

Expansion joints with fixed flanges must be installed with the connecting flanges flush to the pipeline. **Twisting of/torsion** in the metal bellow during assembly and operation is not **permitted**.

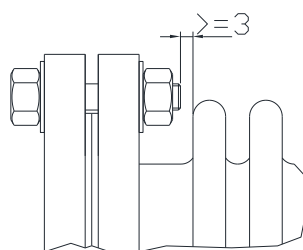



Note on the gasket to be used:

If no gasket was specified by the customer when placing the order, the manufacturer will assume a gasket from Table 1 (AD2000 B8 Edition 2017) that matches to the pressure rating of the compensator in accordance with Section 8.2 AD2000 B8 (Edition 2017). Therefore, a separate flange calculation is not necessary, even for flammable or toxic media (AD 2000 B7 edition 2017). Deviating gaskets are indicated on the component drawing. When installing the compensator, it must be ensured that if no special gasket is specified on the component drawing, a gasket matching the pressure rating of the compensator is used in accordance with Table 1 (AD2000 B8 Edition 2017). If a different gasket is used, it is the customer's / user's responsibility to carry out or arrange a strength calculation of the flanges.

Pretensioning, installation lengths and torsion

The installation length depends on the operating conditions (mainly pretensioning required; $EBL > BL$). The expansion joint absorbs the **lifting motion, originating from its nominal length, each to 50%** in the pressure and tensile direction. Thereby, for the normal case, the expansion joint must be installed in the cold line stretched by 50% of the lift.

For application as an oscillation or noise damper, the expansion joints must be installed without pretensioning, installation length $[EBL] = \text{overall length } [BL]$. The maximum permissible oscillation amplitude during this is $\leq 5\%$ of the unidirectional nominal movement for 1000 load cycles. To prevent further movements, assemble the damping element as close to the oscillating unit as possible. To avoid the risk posed by the vibrating body and therefore by the self-resonance, place an autarchic fixed point or guide bearing immediately behind the oscillation damper.

Fundamentally, when installing all expansion joints, make sure that no adverse tube motion, for example as torsion, acts on the expansion joints.

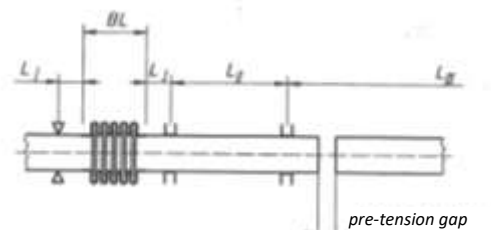
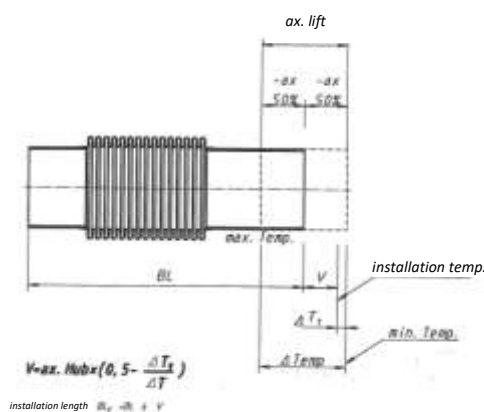



Maintenance

The operating company must determine regular checks conducted by qualified personnel. Depending on the use, checks are recommended once a year, or at shorter intervals. The results of this monitoring should be documented in writing.

Heavily contaminated expansion joints must be cleaned using suitable agents or, as necessary, replaced. When checking, pay attention to deformation of the corrugations or damage to the connecting parts. For questions regarding this, contact the manufacturer. Damaged expansion joints must be replaced. Repairs or modifications to expansion joints must be discussed with Flexomat GmbH and carried out by the appropriate specialists.

Warranty

The warranty conforms to the statutory provisions, in accordance with the specified operating parameters.

Damage due to natural wear, incorrect handling or overloading is not included in the warranty.

Environmental protection

After use, the transportation and packaging material, as well as the product itself, must be disposed of in an environmentally friendly manner.

Expansion joints in accordance with DGRL 2014/68/EU

The stainless steel expansion joints are classified in accordance with DGRL. The use is permitted only for the medium or the fluid group specified in the technical documents.

Non-compliance with these specifications will amount to infringement of the Ordinance on Industrial Safety and Health. This will render the declaration of conformity and the CE mark invalid and the expansion joint will not operate within the framework of the DGRL.





Hazards and risk analysis

Hazards	Measures
Strength failures due to internal or external pressure including the fittings	<ul style="list-style-type: none">- Exceeding the maximum permissible operating pressure, taking into account the manufacturer's specifications in the technical documentation and on the nameplate on the component, is not permitted
Influence of temperature	<ul style="list-style-type: none">- Do not exceed or fall short of the maximum permissible operating temperature, taking into account the manufacturer's specifications in the technical documentation and on the nameplate on the component- Protective clothing (e.g., gloves) against the risk of injury due to outside temperature acting on the component
External stresses on the pressure device	<ul style="list-style-type: none">- Proper piping design with all fixed, slide and floating bearings
Exceeding the permissible movement absorption	<ul style="list-style-type: none">- Do not exceed or fall short of the maximum permissible movements, taking into account the manufacturer's specifications in the technical documentation and on the nameplate on the component
Prevent external damage on the metal bellow	<ul style="list-style-type: none">- Protect the expansion joint from external damage by means of suitable measures- Ideally, remove the outer corrugation protection (e.g., corrugated board + galvanised sheet steel) just before commissioning- Prevent the falling of objects during maintenance and operation- Affix appropriate warning signs
Corrosion/Erosion/Abrasion	<ul style="list-style-type: none">- Inspection of the use of suitable materials for the aggressive medium in cooperation with the manufacturer- Provide suitable means to preserve steel parts against external influences- Protect internal and external fittings (e.g., inner protective tube) against internal and external abrasion or corrosive deposits/reactions



Hazards	Measures
Sharp edges and various fittings (e.g., bracing elements)	<ul style="list-style-type: none">- Wear personal protective clothing- Use appropriate warning signs
Malfunction of the pressure device during operation	<ul style="list-style-type: none">- The operating company must draw up a separate risk assessment- The operating company must determine periodic inspections in accordance with Ordinance on Industrial Safety and Health- These checks must be performed by qualified personnel only- The result must be documented.

Applicable standards

DGRL 2014/68/EU	Current version
DIN EN 14917	Current version
DIN EN 30681	Current version
Ordinance on Industrial Safety and Health (BetrSichV)	Current version
Ordinance on Hazardous Substances (GefStoffV)	Current version

The team from Flexomat GmbH is at your disposal at all times to answer any questions!

Flexomat GmbH
Lindigtstrasse 2
01683 Nossen

Fax: 035242 / 4394-140
Tel: 035242 / 4394-100
email: service@flexomat.de
Internet: www.flexomat.de/shop/en

